

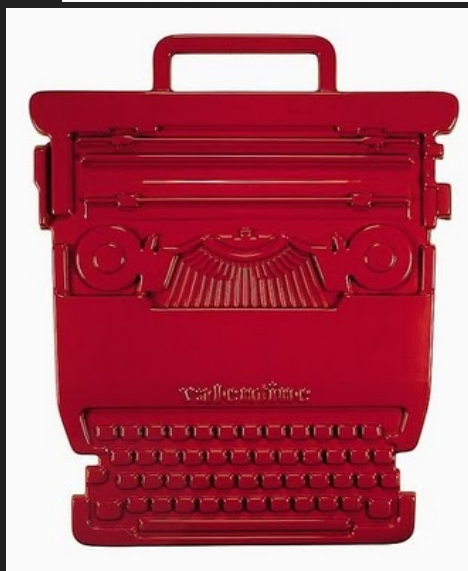

da: <http://bibliodyssey.blogspot.com/2008/05/sottsass-pompidou.html>

ANTONIO GERACE design allievo del corso B prof CECILIA POLIDORI a.a. 2010-2011 giovedì 7 gennaio 2010

ettore sottsass e l'OLIVETTI

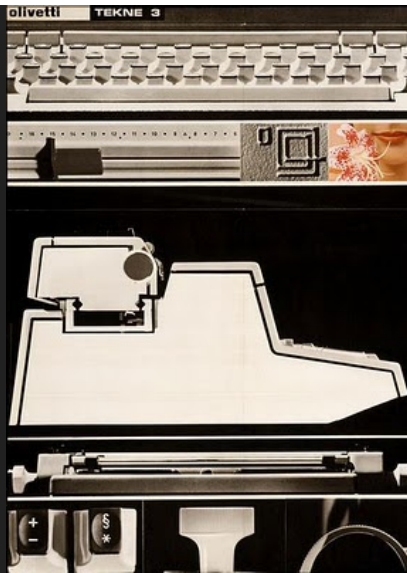



1/07/2010 03:07:00 AM

VALENTINE progett. 1968 produz. 1969

<http://www.thepatentdesk.com/page/4>

Publicato da DESIGN MANHATTAN - MANHATTAN

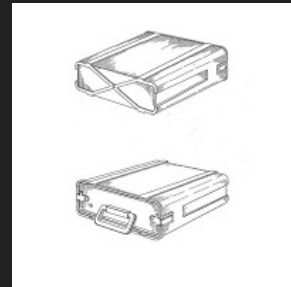
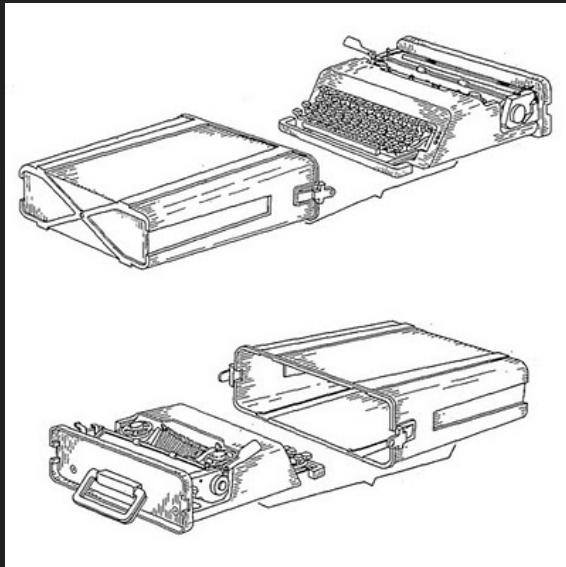



Publicato da DESIGN MANHATTAN - MANHATTAN a 1/07/2010 02:12:00 AM

mercoledì 6 gennaio 2011

olivetti: Valentine







Publicato da DESIGN MANHATTAN - MANHATTAN a 1/06/2010 04:00:00 AM

ettore sottsass: autoritratto

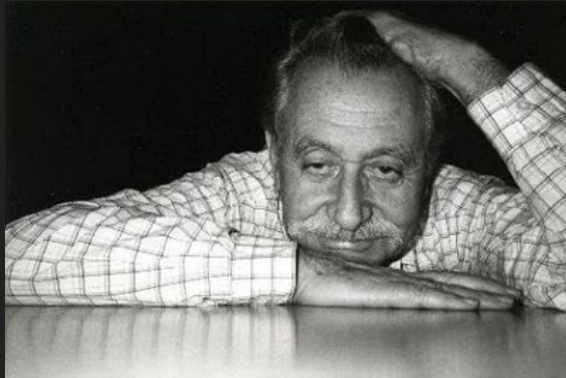

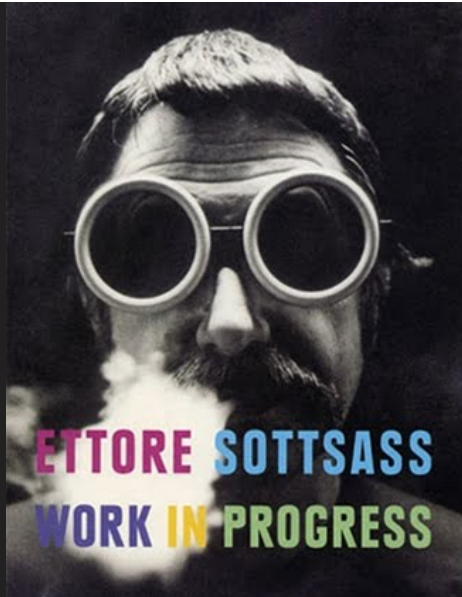

Publicato da DESIGN MANHATTAN - MANHATTAN 1/06/2010 03:03:00 AM

martedì 5 gennaio 2010

MOMA NEW YORK 1972: SUPER STUDIO e SOTTASS



Superstudio, Life without objects < PANKOV

da: supersurface-superstudio-008 < strawdogs

Not enough parameters were given.

Available parameters:

- w = Maximum width
- h = Maximum height
- c = Crop ratio (width:height)
- q = Quality (0-100)
- b = Background fill color (RRGGBB or RGB)
- p = Progressive (0 or 1)

Example usage:

```

```

architecture

Superstudio, "Fundamental Acts: Life, Supersurface", 1972

da:

da: Image, viewpoints on



da: untitled_space

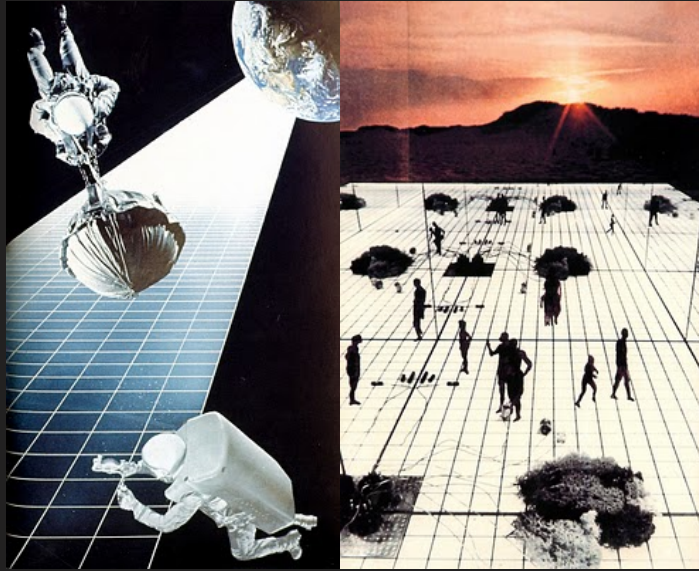

da: DANCE LIKE SHAQUILLE O'NEAL; Superstudio (parte seconda)



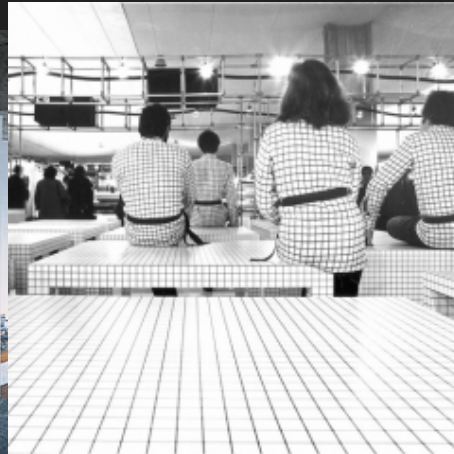

produzione ZANOTTA: tavoli modulari *QUADERNA*, con struttura in legno tamburato placcato in laminato Print, colore bianco stampato in serigrafia a quadretti neri con interasse di 3 cm. Progettato da Superstudio nel 1966 - il gruppo fondato a Firenze da Cristiano Toraldo di Francia e Adolfo Natalini; in produzione dal 1970 da Zanotta, che non ha mai smesso di riprodurlo.

ETTORE SOTTASS DISEGNO DI UN MODULO PER AMBIENTE DOMESTICO FLESSIBILE, MOMA, 1972



Publicato da DESIGN MANHATTAN - MANHATTAN/05/2010 09:58:00 PM
ettore sottsass al MOMA di New York, 1972: ABITACOLO

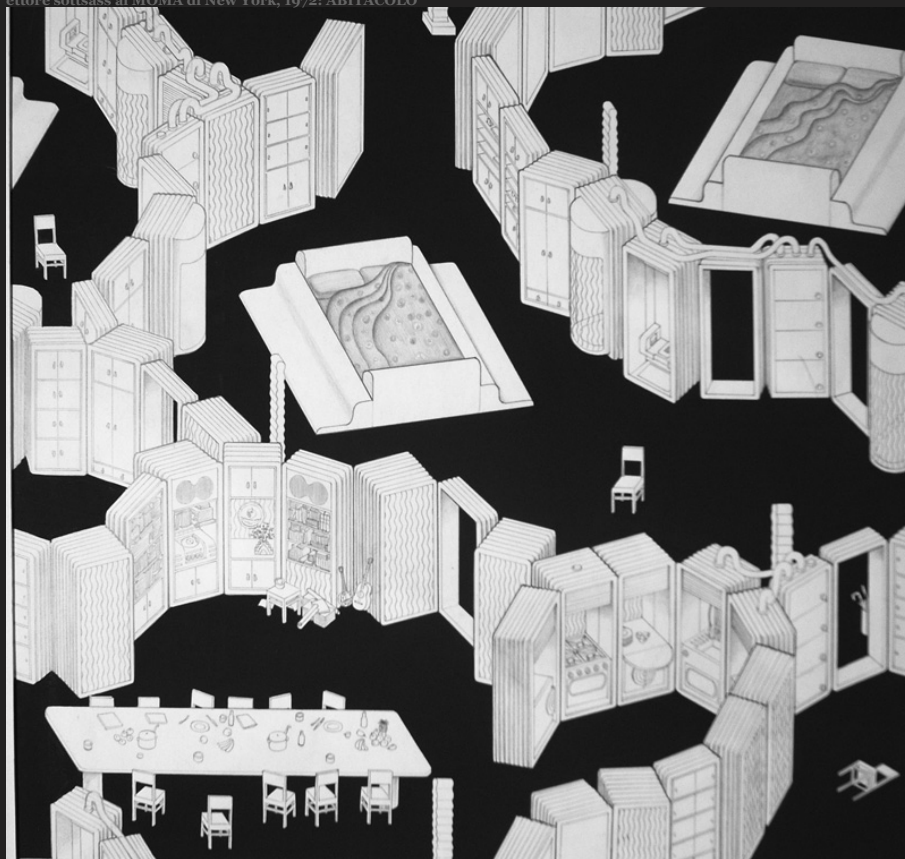

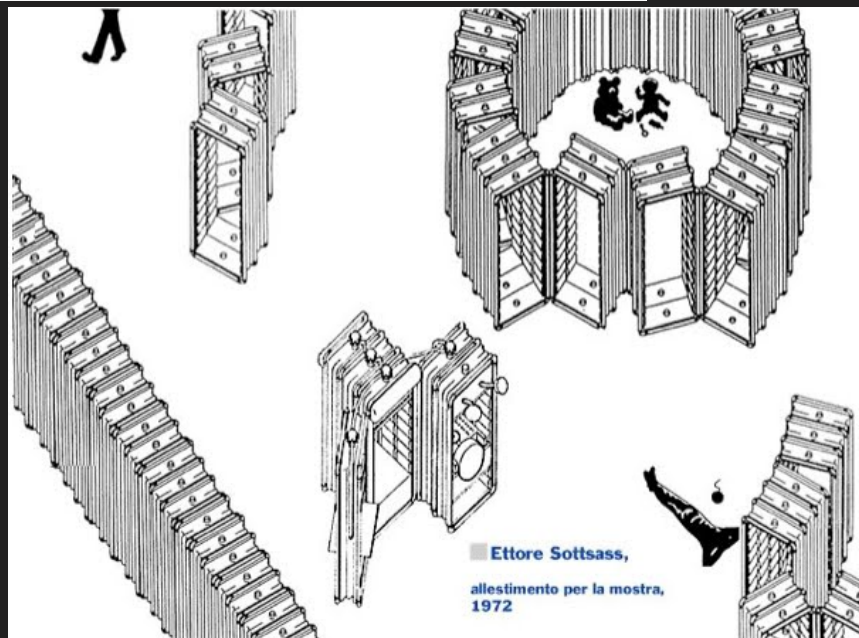
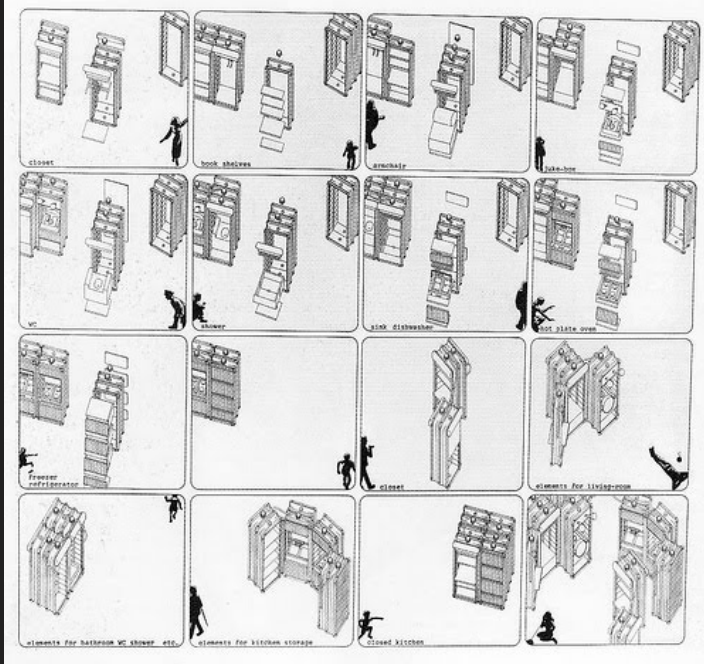

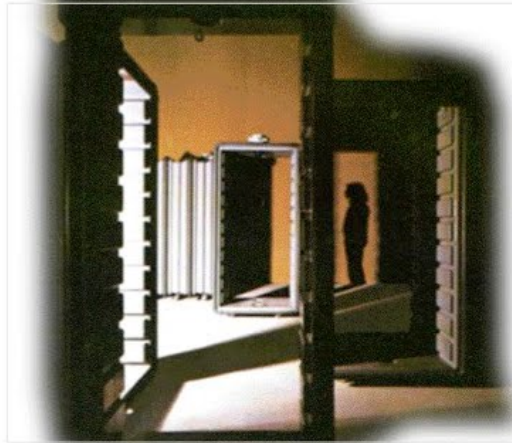
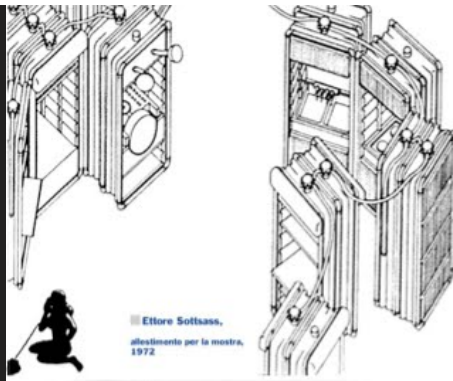

■ Ettore Sottsass,
allestimento per la mostra,
1972



■ Ettore Sottsass,
allestimento per la mostra,
1972



■ Ettore Sottsass,
allestimento per la mostra,
1972



da: [Environments and Counter-Environments](#)

[Experimental Media in Italy](#)

[The New Domestic Landscape. MoMA 1972 - YMAG - magazine architettura, design, altri riflessi dal futuro padiglione italia biennale di venezia - by viapiranesi](#)

Publicato da DESIGN MANHATTAN - MANHATTAN a 1/05/2010 03:13:00 AM

lunedì 4 gennaio 2010

ettore sottsass: componenti per i punti vendita FIORUCCI, 1980 1983

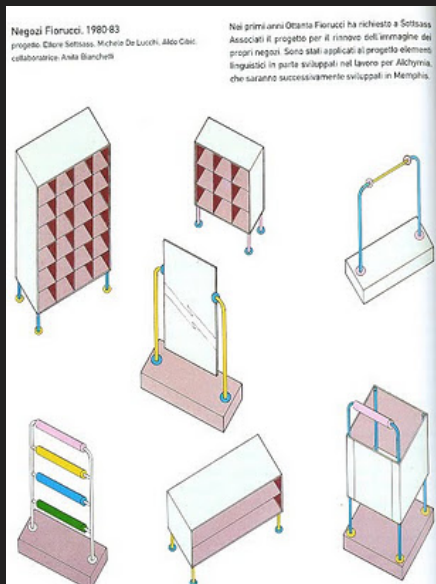

Publicato da DESIGN MANHATTAN - MANHATTAN a 1/04/2010 10:20:00 PM

MEMPHIS & ELVIS

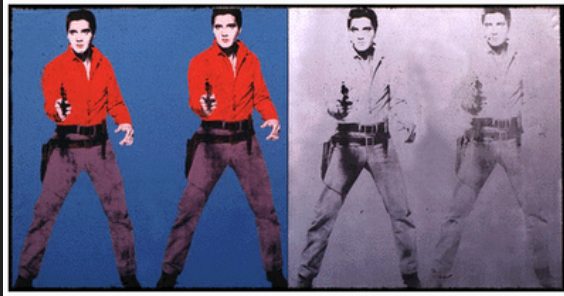
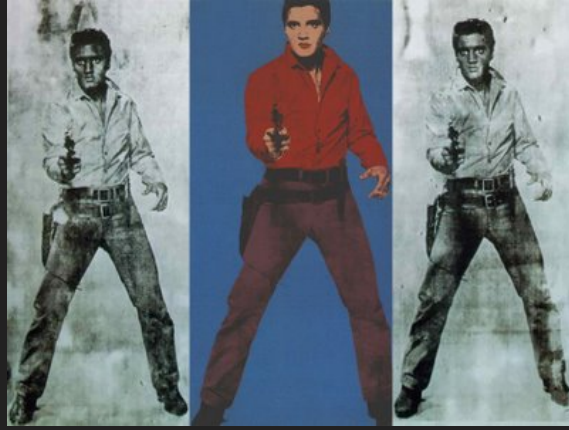

la casa di Elvis: Graceland, ed il muro di cinta con i graffiti dei visitatori (foto Cecilia Polidori)





GRACELAND, MEMPHIS, TENNESSEE, AGOSTO 2010 -
FOTO CECILIA POLIDORI

Publicato da DESIGN MANHATTAN - MANHATTAN a 1/04/2010 10:18:00 PM

ettore sottsass: disegni

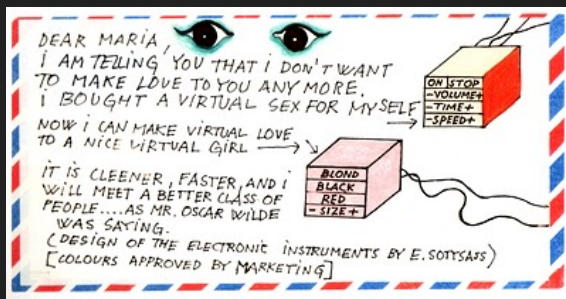
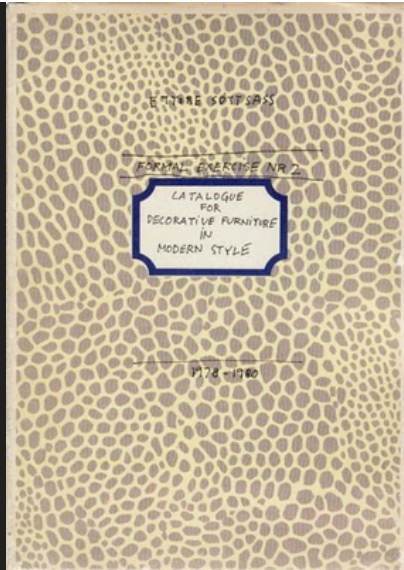

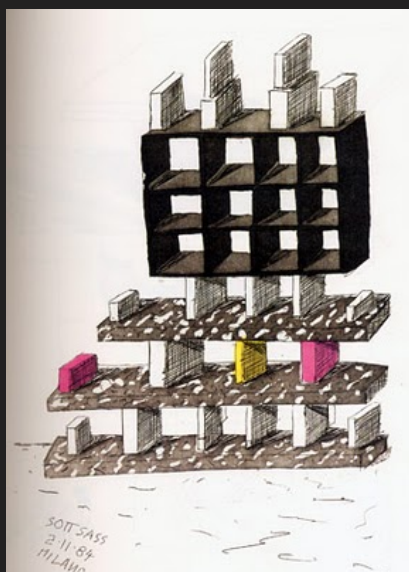
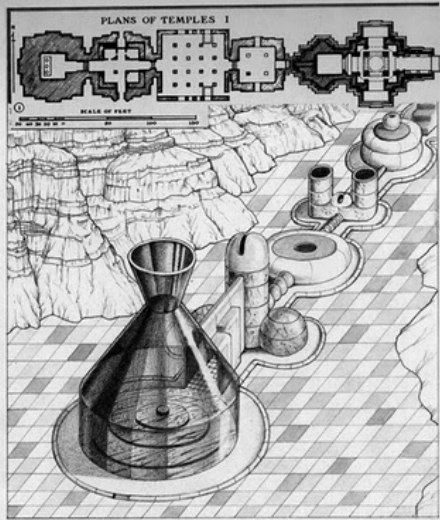

Publicato da DESIGN MANHATTAN - MANHATTAN a 1/04/2010 05:19:00 PM
domenica 3 gennaio 2010

MEMPHIS PATTERNS

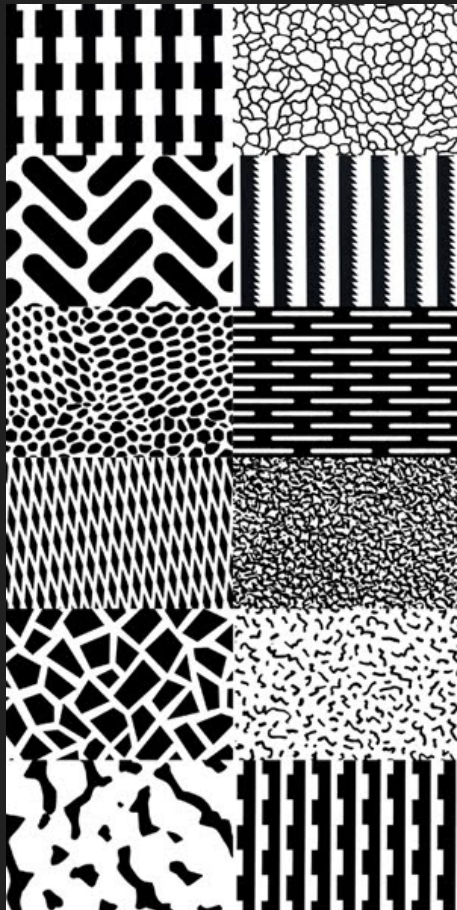

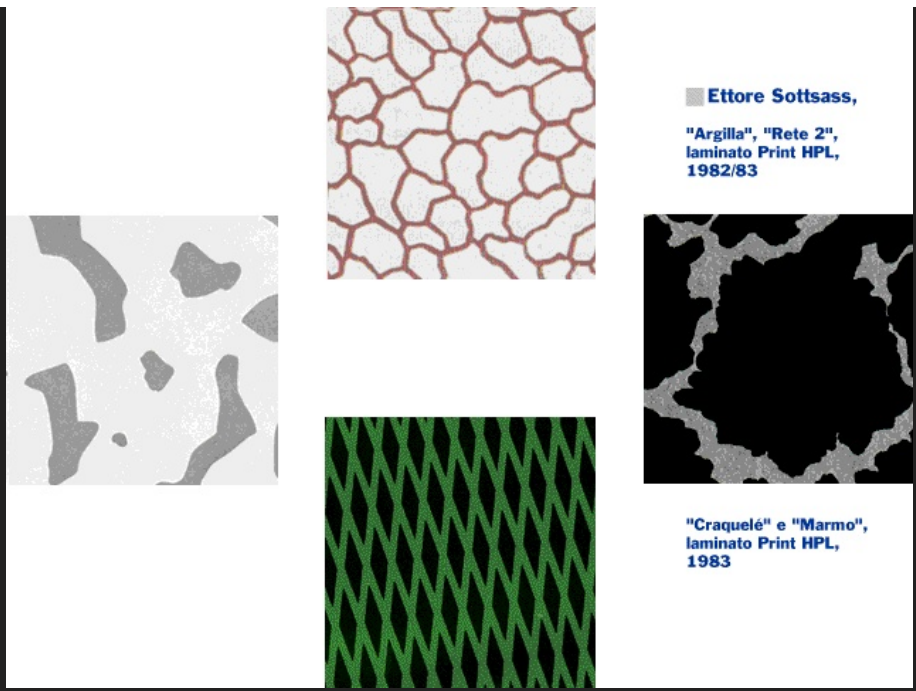

Ettore Sottsass,
"Argilla", "Rete 2",
laminato Print HPL,
1982/83

"Craquelé" e "Marmo",
laminato Print HPL,
1983

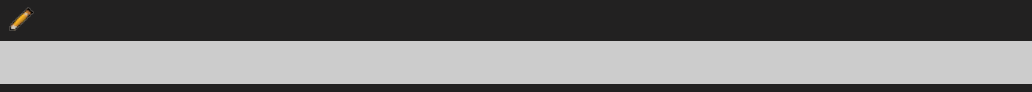
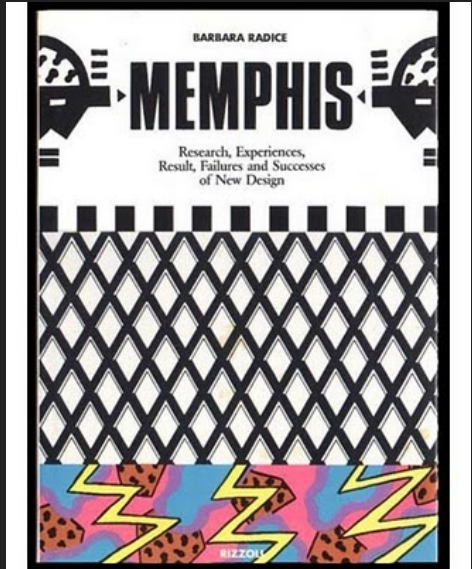

Home page

Iscriviti a: [Post \(Atom\)](#)

Charles EAMES 1956 & Paolo DEGANELLO 1973 & Pierre Paulin 1965

[EGODESIGN.CA](#) Le premier magazine Web canadien dédié au design global
[From the Archives: Eames Lounge Chair Début, 1956](#)
[Charles Eames \(1907–78\) and Ray Eames \(1912–88\) | Thematic Essay | Heilbrunn Timeline of Art History | The Metropolitan Museum of Art](#)
[paolo deganello AeO 1973 produz Cassina](#)
[Storia del design francese: Pierre Paulin | Krea casa blog](#)
[Tulip Chair 1965](#)

Ricerca Design & Lezioni di design



ARCH'IT Books / Lorenzo Imbesi, Hans Höger (a cura di), Ricerche Design
<http://www.educational.rai.it/LEZIONIDIDESIGN/home/index.htm>
 Home Page / Indice dei protagonisti /Indice degli oggetti/etc.



Karim Rashid

karim rashid

Casa oggi modi di vivere il loft in Design, Arredamento | www.dibaio.com



Karim Rashid's Window Inspiration - Marvin Windows and Doors

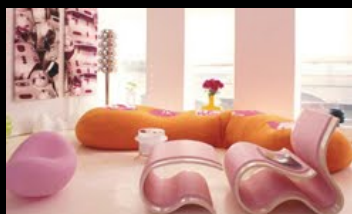

http://www.youtube.com/watch?v=ci7S8cgoHQQ&feature=player_embedded



Archivio blog

► [2010](#) (11)



Informazioni personali



DESIGN MANHATTAN - MANHATTAN

IO PROGETTO CON GLI ALLIEVI – I DESIGN WITH MY STUDENTS. Il progetto, il prototipo, non è tanto significativo in sé, quanto il fatto che sia una variante tra altre 50, 100, anche 180, realizzate contemporaneamente. Tutti noi che mostriamo le nostre anime... Insegnare design per me significa progettare insieme ad ogni mio singolo allievo, in un team di lavoro composto in corsi molto numerosi e frequentati - il mio lavoro è con circa 250-300 allievi l'anno - Il tema, lo spunto che fornisco come idea iniziale, può essere sviluppato in un'esercitazione breve o di mesi; con l'occasione progettuale cerco di offrire tutti gli stimoli, i suggerimenti e gli esempi del caso. Inoltre dalla realizzazione vera e propria dell'oggetto al vero in scala 1:1, si passa a contestualizzarlo con l'ambientazione, rendering, impaginazione, sino alla sua presentazione in book con foto, video e gadgets: quali segnalibri, t-shirt, cartoline, calendari. I materiali sono semplici da recuperare e da trasportare in aula ogni volta, e, in genere, sono riutilizzati: carta, stoffa, foglie, anche di fico d'india, rami e legni, lacci, spaghi, plastica, pezzi di vetro recuperato sulla spiaggia, etc...

[Visualizza il mio profilo completo](#)



SITI WEB AD USO DIDATTICO 2010 PROF POLIDORI

CECILIA POLIDORI DESIGN Lezioni

[cecilia polidori per allievi design 2 - 2011](#)
[CECILIA POLIDORI DESIGN temi sperimentali](#)
[Facolta' di Architettura - Scheda persona](#)
[CECILIA POLIDORI DESIGN](#)
[CECILIA POLIDORI ONCE MORE DESIGN](#)
[CECILIA POLIDORI LE ALI DEL DESIGN](#)
[CECILIA POLIDORI USA](#)
[CECILIA POLIDORI DESIGN allievi corso di DISEGNO INDUSTRIALE A e B a.a. 2010- 2011](#)
[Cecilia Polidori Design](#)
[Design al 38esimo parallelo](#)
[Wizard - http://xoomer.virgilio.it/diseagnoindustriale5](http://xoomer.virgilio.it/diseagnoindustriale5)
[Wizard - http://xoomer.virgilio.it/diseagnoindustriale3](http://xoomer.virgilio.it/diseagnoindustriale3)
[Home - http://utenti.multimania.it/diseagnoindustriale3](http://utenti.multimania.it/diseagnoindustriale3)

CECILIA POLIDORI WEB SITES: WORK IN PROGRESS

[CECILIA POLIDORI DESIGN](#)
[cecilia polidori il mio design](#)
[cecilia polidori design USA 2011](#)
[CECILIA POLIDORI USA 2010 FOTOREPORTAGE](#)
[CECILIA POLIDORI USA REPORTAGE 2010](#)
[Facolta' di Architettura - Scheda persona](#)
[CECILIA POLIDORI DESIGN Lezioni - 2010 2011](#)
[CECILIA POLIDORI DESIGN allievi corso di DISEGNO INDUSTRIALE 2010-2011 - BLOG PILOTA 1](#)
[cecilia polidori per allievi design 2 - 2011](#)
[CECILIA POLIDORI DESIGN allievi 3: si torna al tridimensionale](#)
[cecilia polidori design allievi 4: video](#)
[CECILIA POLIDORI DESIGN ALLIEVI 5](#)
[CECILIA POLIDORI DESIGN temi sperimentali](#)
[CECILIA POLIDORI LE ALI DEL DESIGN - THE WINGS OF DESIGN 2009](#)
[CECILIA POLIDORI ONCE MORE DESIGN 2009](#)
[disegno industriale 3 ROMA - 2005 2006](#)
[disegno industriale 3 Reggio Calabria - 2005 2006](#)
[disegno industriale 5 ROMA - 2004 2005](#)
[Design al 38° parallelo - 2003 2004](#)
[Cecilia Polidori Design - 2001 2003](#)

ALL IMAGES ON THIS SITE COPYRIGHT ©2011 CECILIA POLIDORI OR THEIR RESPECTIVE OWNERS. CECILIA POLIDORI TUTTI I DIRITTI SONO RISERVATI E PROTETTI DA COPYRIGHT.

CECILIA POLIDORI TUTTI I DIRITTI SONO RISERVATI E PROTETTI DA COPYRIGHT. Modello Travel. Powered by [Blogger](#).