

Le Corbusier *Natura morte puriste*, studio per *Natura Morta*, 1922

Le Corbusier (Charles-Édouard Jeanneret) (6 ottobre 1887, **La Chaux-de-Fonds, Svizzera** - 27 agosto 1965, **Roquebrune-Cap-Martin, Francia**) *Still Life/ Natura morta con pila di piatti*, olio su tela/ oil on canvas, 1920, MOMA Museum NYC (Museum of Modern Art, New York), 80.9 x 99.7 cm.

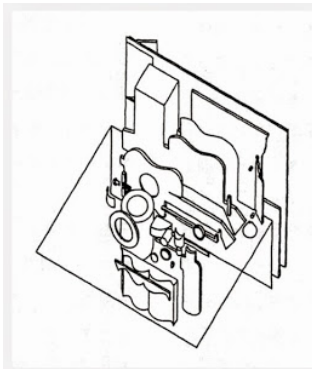

"Sono nato per guardare immagini e per disegnare.
E ancora: Il fondo della mia ricerca e della mia produzione intellettuale ha il suo segreto nella pratica ininterrotta della pittura...".

vedi: Flaminio GUALDONI, *Le Corbusier. La pittura, in Le Corbusier pittore scultore designer*, catalogo, Civica Galleria d'Arte Moderna, Lissone, 23 marzo - 15 giugno 2003
- [Flaminio Gualdoni](#) » [Blog Archive](#) » [Le Corbusier](#) - <http://flaminiogualdoni.com/?p=455>





Le Corbusier - foto Nina Leen, 1946 - LIFE







Le Cabanon 1949

Aveva ragione Le Corbusier quando si ritirò a Roquebrune-Cap-Martin in quella specie di palafitta-cabina "Le Cabanon" 1948-49, che aveva realizzato - già quindici anni prima della morte - come luogo con il necessario (ovvero semplificato) in una cabina/cubo di legno di 3,36 x 3,36 sul mare... che stupida! quando anch'io ero studentessa di Architettura, pensavo ad un ritiro frustrato, invece vedo che è sempre più il mio obiettivo: semplificare ed eliminare, si vive meglio, si risparmia tempo, si vive davvero ...

da: LE CORBUSIER, *L'art décoratif d'aujourd'hui*, Paris, (trad. it: *Arte decorativa e design*, ed. Laterza, Bari, 1972, pp. XVI, XVII, XVIII).

ofr: Cherubino GAMBARDILLA, "LE CABANON", LABORATORIO DI PROGETTAZIONE ARCHITETTONICA 1 a.a. 2013 / 2014, SECONDA UNIVERSITA' DEGLI STUDI DI NAPOLI. DIPARTIMENTO DI ARCHITETTURA E DISEGNO INDUSTRIALE CORSO DI LAUREA IN ARCHITETTURA

scaricabile da: <http://www.architettura.unina2.it/docenti/aresprivata/65/documenti/LE%20CABANON.pdf>



Charlotte Perriand sur la Chaise Longue Basculante, Le Corbusier, Jeanneret, Perriand, 1928



